

Fork Mounted Boom - Low Profile

Offering all the same characteristics as our under-slung forklift boom, this forklift boom is designed however with a low profile design, making it better suited for handling rolls or coiled products that are stacked. An example of this would be loading or unloading stacked rolls from a lorry.

The fork mounted design of the forklift boom allows the truck operator quick changeover from pallet handling to roll handling with little downtime, ideal for when time is at a premium.

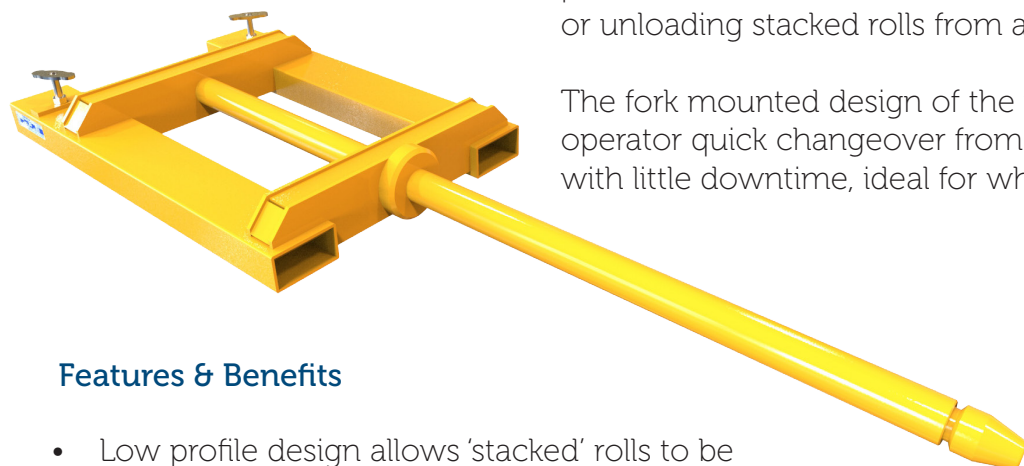

Features & Benefits

- Low profile design allows 'stacked' rolls to be handled whilst giving truck operator increased visibility
- Free standing 'drive in' design only requires the truck operator to fit the boom, reducing downtime and standing time
- High grade EN19T steel, offering strong, durable and long service life properties
- Leading edge nose cone designed to avoid damage to the roll being handled whilst offering easy 'glide in' pick up
- Twin heel retention pins to ensure the forklift boom is safely and securely fastened to the lift truck forks

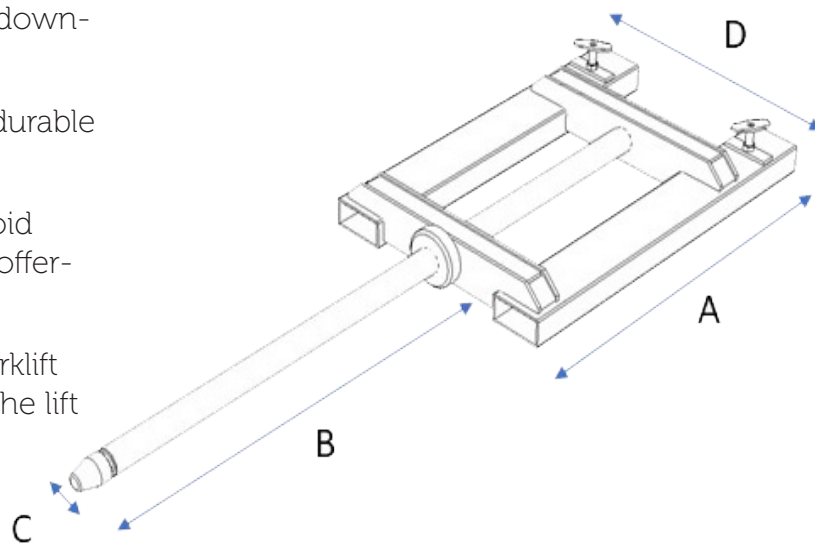

Model Ref	Max SWL @ 500mm	"A" Lost Load Centre	"B" Pole Length	"C" Pole Diameter	"D" Fork Spread	Max Fork Size
LPB 50	1000kg	1140mm	Upto 4000mm	50mm	730mm	140 x 55mm
LPB 65	1250kg	1140mm	Upto 4000mm	65mm	730mm	140 x 55mm
LPB 70	1500kg	1140mm	Upto 4000mm	70mm	730mm	140 x 55mm
LPB 75	2000kg	1140mm	Upto 4000mm	75mm	730mm	140 x 55mm