

Our under-slung forklift boom attachment is the perfect solution for when you need to utilise your forklift truck for handling rolls or coiled products.

The fork mounted design of the forklift boom allows the truck operator quick changeover from pallet handling to roll handling with little downtime, ideal for when time is at a premium.

## Features & Benefits

- Under-slung design ensures the roll is kept to the lift truck, reducing the necessity for using larger capacity lift trucks
- Free standing 'drive in' design only requires the truck operator to fit the boom, reducing downtime and standing time
- high grade EN19T steel, offering strong, durable and long service life properties
- Leading edge nose cone designed to avoid damage to the roll being handled whilst offering easy 'glide in' pick up
- Twin heel retention pins to ensure the forklift boom is safely and securely fastened to the lift truck forks

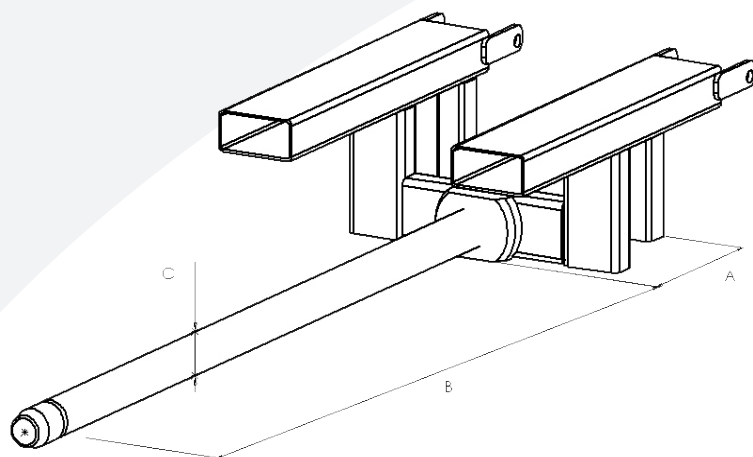

We manufacture our forklift booms to order to ensure the roll diameter and under-slung nature of the design does not cause any conflict with your forklift truck forks.

Model Ref	Max SWL @ 500mm	"A" Lost Load	"B" Pole Length	"C" Pole Diameter	Max Fork Size
FMB 50	1000kg	370mm	Up to 4000mm	50mm	140 x 55mm
FMB 65	1250kg	370mm	Up to 4000mm	65mm	140 x 55mm
FMB 70	1500kg	370mm	Up to 4000mm	70mm	140 x 55mm
FMB 75	2000kg	370mm	Up to 4000mm	75mm	140 x 55mm
FMB 90	3000kg	370mm	Up to 4000mm	90mm	140 x 55mm